

Intensif février Digital Knowledge

Robotique & contrôle : préfabrication et assemblage

Intensifs : présentation générale

Mardi 11 février 2014, 9h30-19h00

ENSAPM, Bâtiment Perret, Salle 308

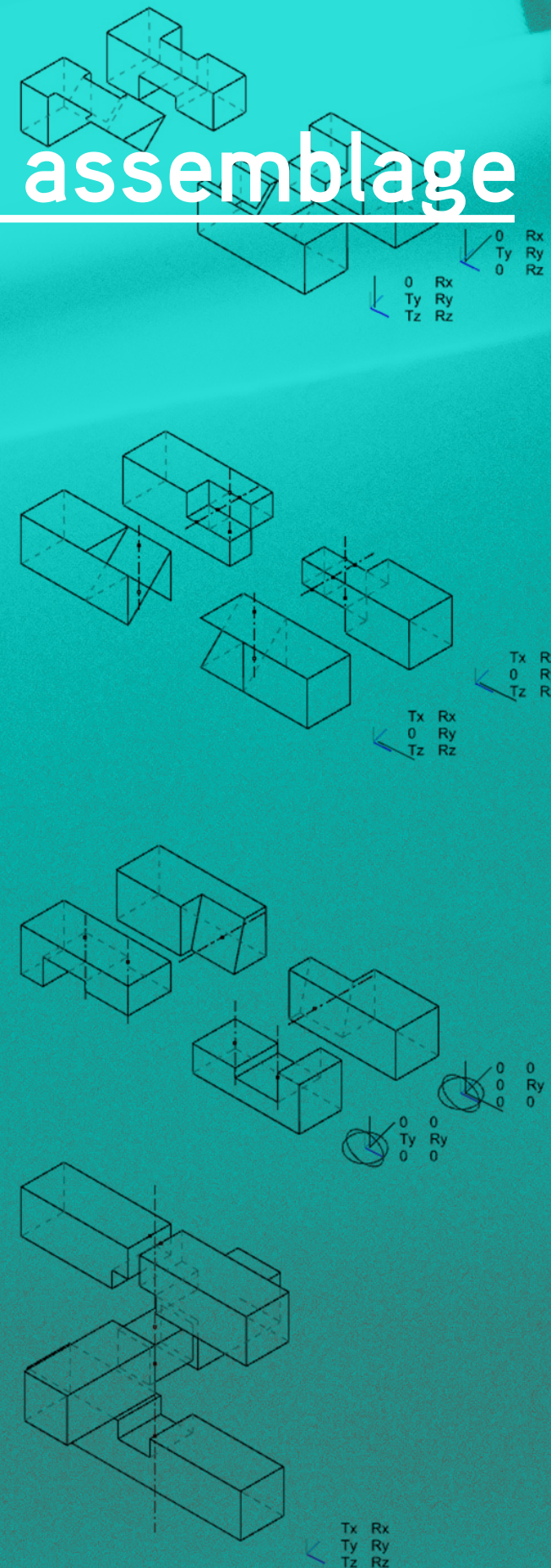

Digital
Knowledge
www.digital-knowledge.net

ABB

Projet réalisé par:

Alexandre ATAMIAN

Leo DEMONT

Alice FLORIN

Yassir RAÏS

Présentation du projet

Notre objectif était de réaliser un volume tirant parti des possibilités offertes par le robot. Pour cela, nous souhaitons créer un module développable dans l'espace. Ce module devait permettre une certaine circulation de la lumière. Nous devons donc réfléchir aux connexions des modules entre eux tout en conservant une porosité visu-

elle ainsi qu'une relative complexité formelle de manière à identifier les problèmes et enjeux d'un usinage sur 6 axes.

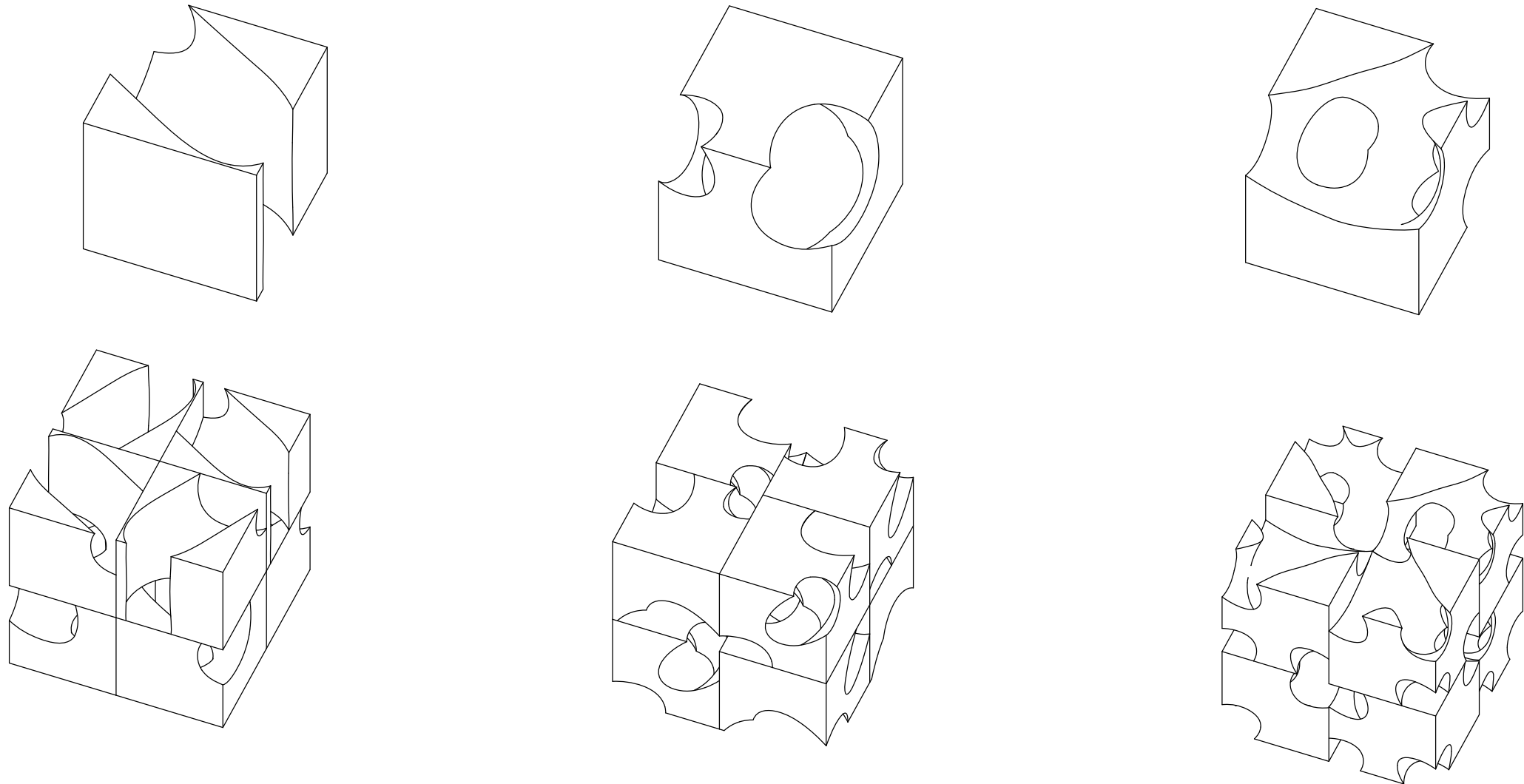

Expérimentations de modules

Solution Retenue

Nous avons décidé de construire notre volume en partant d'un cube évidé selon 4 axes de manière à conserver une symétrie permettant la connexion des modules entre eux.

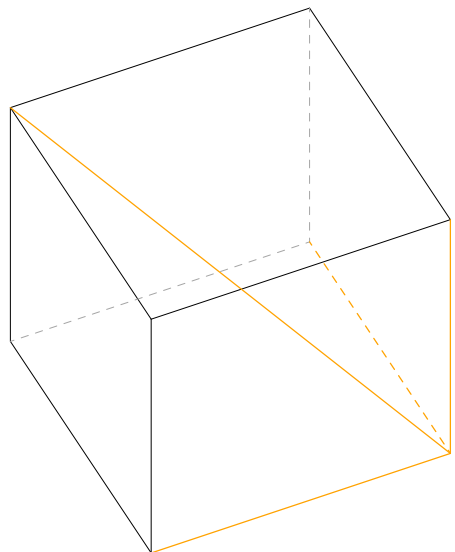
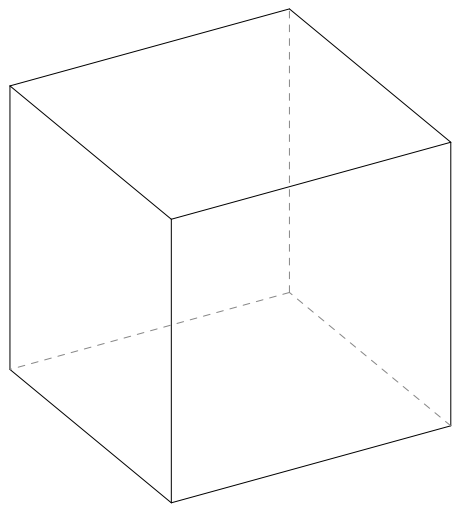

Mise en évidence des axes

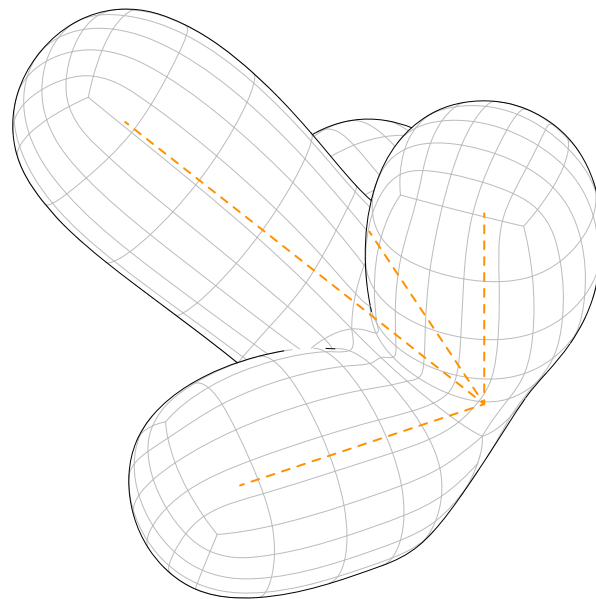

Volume obtenue à partir des axes et du plugin Tsplines pour Rhinoceros.

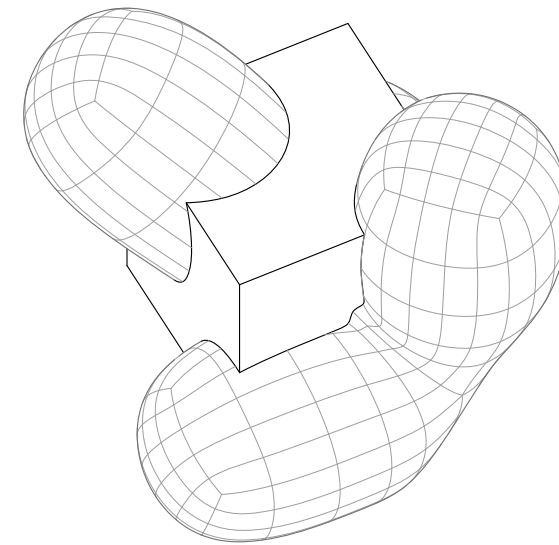
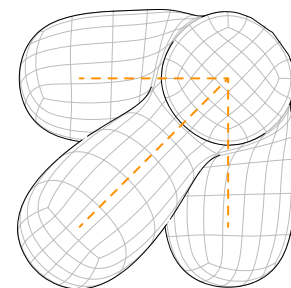
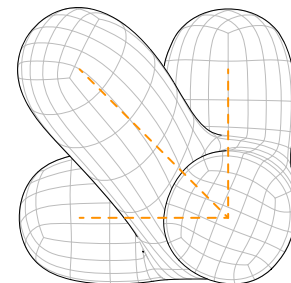
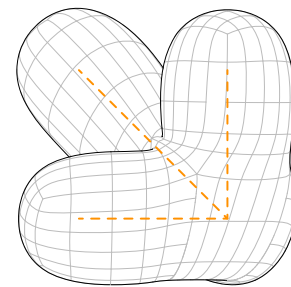

Opération Booléenne entre le volume obtenue et le cube

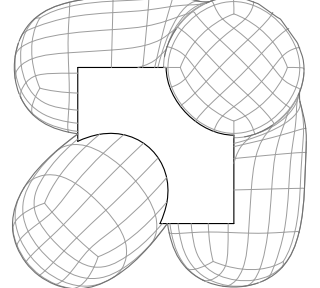
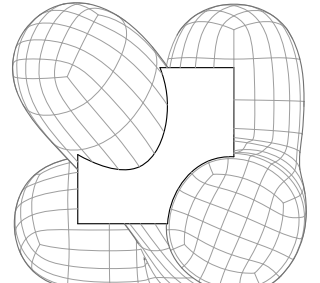
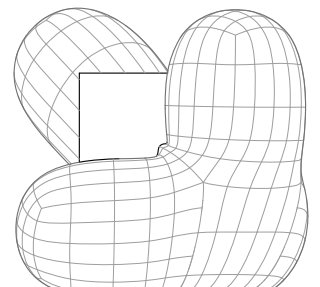

Développement dans l'espace

